

Aberdeen Planning Guidance 2023: Repair and Replacement of Cast Iron Railings

Table of Contents

1. Introduction	Page 2
1.1 Status of Aberdeen Planning Guidance	Page 2
1.2 Introduction to Topic	Page 2
1.3 Climate Change	Page 2
1.4 Health and Wellbeing	Page 3
2. Aberdeen Planning Guidance	Page 4
2.1 Characteristics of Cast Iron	Page 4
2.2 Reinstatement, Replacement, Repairs and Restoration	Page 4
2.3 Dismantling and Reassembly	Page 5
2.4 Reinstatement with New Ironwork	Page 5
2.5 General Guidance Matters	Page 5
2.6 Authenticity	Page 6
2.7 Consents	Page 6
3. Further Reading	Page 7
Appendix 1: Repair or re-instatement of cast iron railings - detail drawings	Page 8
Appendix 2: Cold and Welded Repairs	Page 10

1. Introduction

1.1 Status of Aberdeen Planning Guidance

This Aberdeen Planning Guidance (APG) forms part of the Development Plan and is a material consideration in the determination of planning applications.

This APG expands upon the following Aberdeen Local Development Plan policies:

- Policy D1 – Quality Placemaking
- Policy D6 – Historic Environment

Given the timing of the Local Development Plan, a pragmatic approach has been taken to changes in the planning system. National Planning Framework 4 (NPF4) was adopted following the examination and subsequent modification of the Local Development, and the publication of a draft version of this APG for consultation. As a result, some terminology referred to in this APG may vary from the new NPF4 policy framework but it should be noted that the LDP together with NPF4 now forms the basis of the statutory development plan.

1.2 Introduction to Topic

Prior to 1940, Aberdeen had retained most of the cast iron railings that enclosed the front gardens and basement areas of many of its Georgian and Victorian buildings. Unfortunately, many of these were removed during the Second World War, purportedly to provide material for munitions, but which, in the event, was simply a morale boosting exercise.

Many of the railings that remain are in need of repair or replacement. There is much interest in re-instating the original type of railings where these had previously been removed.

This leaflet gives guidance on appropriate methods of repair and on suitable specifications for new and replacement railings.

1.3 Climate Change

This guidance has been drafted in accordance with concerns raised through the Climate Emergency. The guidance which supports Policy D6 sits alongside strategies produced by Aberdeen City Council (ACC) such as Net Zero Vision for Aberdeen, Strategic

Infrastructure Plan (Energy Transition), Aberdeen Adapts: Climate Adaptation Framework and the Council's Climate Change Plan, Net Zero Aberdeen RouteMap. Both the Policy and the guidance aim to reflect the values and objectives highlighted within these strategies moving forward to prepare Aberdeen City for the Climate Emergency.

The document aligns with Aberdeen Adapts Goal 1 'Protecting buildings and Historic Assets'. Stonecleaning can be detrimental to buildings and must be carried out properly to ensure no damage or decay to buildings.

1.4 Health and Wellbeing

Where we live, where we work, and where we spend our time has an important influence on our health and wellbeing. How places are designed within their urban or natural environment are vital to the health of the people and communities within them. This guidance can help to achieve the following Public Health Priorities for Scotland - Priority 1: A Scotland where we live in vibrant, healthy and safe places and communities.

This guidance is deemed to have minimal impact on the population health and wellbeing. This means that, whilst it is unlikely a HIA screening report will be requested, this depends on the detail and scope of the application. There may be elements of the proposals that relate to the health and wellbeing of the population that warrant consideration. If that is the case, then a screening HIA will be required.

2. Aberdeen Planning Guidance

2.1 Characteristics of Cast Iron

Cast iron's most useful property was its ability to be cast into a wide variety of shapes at low cost for both practical and ornamental applications. In the 19th and early 20th centuries, the large number of foundries in and around Glasgow produced highly intricate designs of railings and items of street furniture such as lamp standards. Many of the ornate patterns of cast iron railings can still be seen in Glasgow today although much of it is in need of repair. The railings used in other Scottish cities, Aberdeen included, were, in comparison, much simpler.

Whilst being very hard and durable, cast iron is also extremely brittle, and is therefore highly vulnerable to impact damage. Being brittle, it does not tolerate movement very readily and subsidence of the plinth wall into which railing balusters are set, is liable to cause cast iron work to snap under stress. Fortunately, the coping rails are generally formed in wrought iron and can accommodate movement more readily over time.

Although, because of its high carbon content, cast iron is less prone to corrosion than other ferrous metals, it must nevertheless be checked regularly for signs of rusting and repainted as required. Failures due to corrosion commonly occur at the base of the balusters, and at the junction with the wrought iron where electrolytic action between the wrought and cast iron can arise.

Any component of a railing system requiring to be replaced, should be substituted in an identical material. Cast aluminum, glass reinforced plastic or mild steel are not normally suitable substitutes although mild steel can replace wrought iron in the coping rail. Mild steel balusters which have been hot dipped galvanised, can replace cast iron ones, but this is generally not recommended.

2.2 Reinstatement, Replacement, Repairs and Restoration

In circumstances where gates and railings exist, particularly where the railings are original, there will be a presumption in favour of repair and reinstatement. In circumstances where the original material is beyond repair, replacement of the railings using a replicated solution will be acceptable. A design solution of railings and finials that is sympathetic to the local surrounding context may also be acceptable. Reuse of existing holes in a plinth/cope is encouraged where this is compatible with the historic fabric. Railings that float above the plinth may be acceptable in certain circumstances. See detailed guidance for repair and reinstatement provided within the Traditional Care Hub, link provided in the further reading section below.

Before any repair work is carried out, the cause of the damage to the railing must first be rectified. This may entail the re-leveling of the stone plinth or the relieving of any stress applied to the railing from any other source. Guidance on cold and welded repairs is available in appendix 1.

2.3 Dismantling and Reassembly

Where damage to a railing is extensive it may be simpler to dismantle the railing to carry out repairs. Badly damaged sections should be replaced using original railings and finials as patterns. Old iron stumps in the plinth stones should be carefully removed with a diamond-tipped core drill, and the new balusters set into the sockets with molten lead. The lead should be poured slightly proud of the top of the plinth stone to prevent water collecting and possibly leading to corrosion. When railings are being dismantled, the opportunity should be taken to thoroughly clean off old paint and rust, before re-priming and painting.

2.4 Reinstatement with New Ironwork

Where the original railings have been completely removed, the new railings should be as faithful a copy of the original railings, as possible. If none of the original railings can be obtained for use as a guide, then photographic or other archive evidence should be obtained to ascertain the nature of the original railings. In this connection, the Local Studies section of the Public Reference Library on Rosemount Viaduct may be of some assistance. If all such enquiries prove unsuccessful then a reasoned estimate of what the pattern of the railings had originally been can sometimes be made by examining the railings on similar, or nearby streets, or those erected at other properties of the same era. Cast iron is the preferred material for replacements, mild steel may be acceptable in circumstances where the appearance of the material will not have a detrimental impact to the surrounding context. Baluster head and finials will be finished in cast iron.

2.5 General Guidance Matters

1. The conservation principle of minimal intervention should be borne in mind when undertaking work to existing railings.
2. Where possible, repair is preferable to replacement.
3. Any repair should be reversible.
4. When reinstating original railings or fitting new replicas, any opportunity to correct original constructional design weaknesses should be taken.
5. Constructional details which could result in the retention of water should be avoided, as this may lead to corrosion.

6. The individual pieces of a railing should be separately primed before fixing into position, particularly the ends of balusters which are to be set into the plinth sockets.
7. Once fitted, the railings should be regularly inspected and suspect areas cleaned off, re-primed and re-painted. Overzealous, regular repainting should be avoided, as this can lead to a loss of ornamental detail through an excessive buildup of paint.

2.6 Authenticity

It is important that any railings scheme is as near to the original in all respects as is possible. Most remaining original railings in Aberdeen have a simple but robust design. If, in any restoration scheme, the original pattern of railing cannot be established, it is generally safer to copy existing original railings from elsewhere in the city, than to choose something from a catalogue. In the interests of authenticity, it is extremely important that uprights of adequate thickness are specified. Left to their own devices, contractors will frequently fit uprights of 19mm diameter or less, when the minimum diameter of upright should be 24mm. Even a 5mm difference can result in railings that appear too spindly and the whole effect can be compromised.

2.7 Consents

Planning permission and/or listed building consent may be required for the reinstatement of railings that were removed some time ago.

3. Further Reading

Further information is available on the Council's Traditional Building Care Hub webpage:

<https://www.aberdeencity.gov.uk/services/planning-and-building/building-conservation-and-heritage/listed-buildings/traditional-and-historic-buildings-conservation-advice>

Appendix 1: Repair or re-instatement of cast iron railings - detail drawings

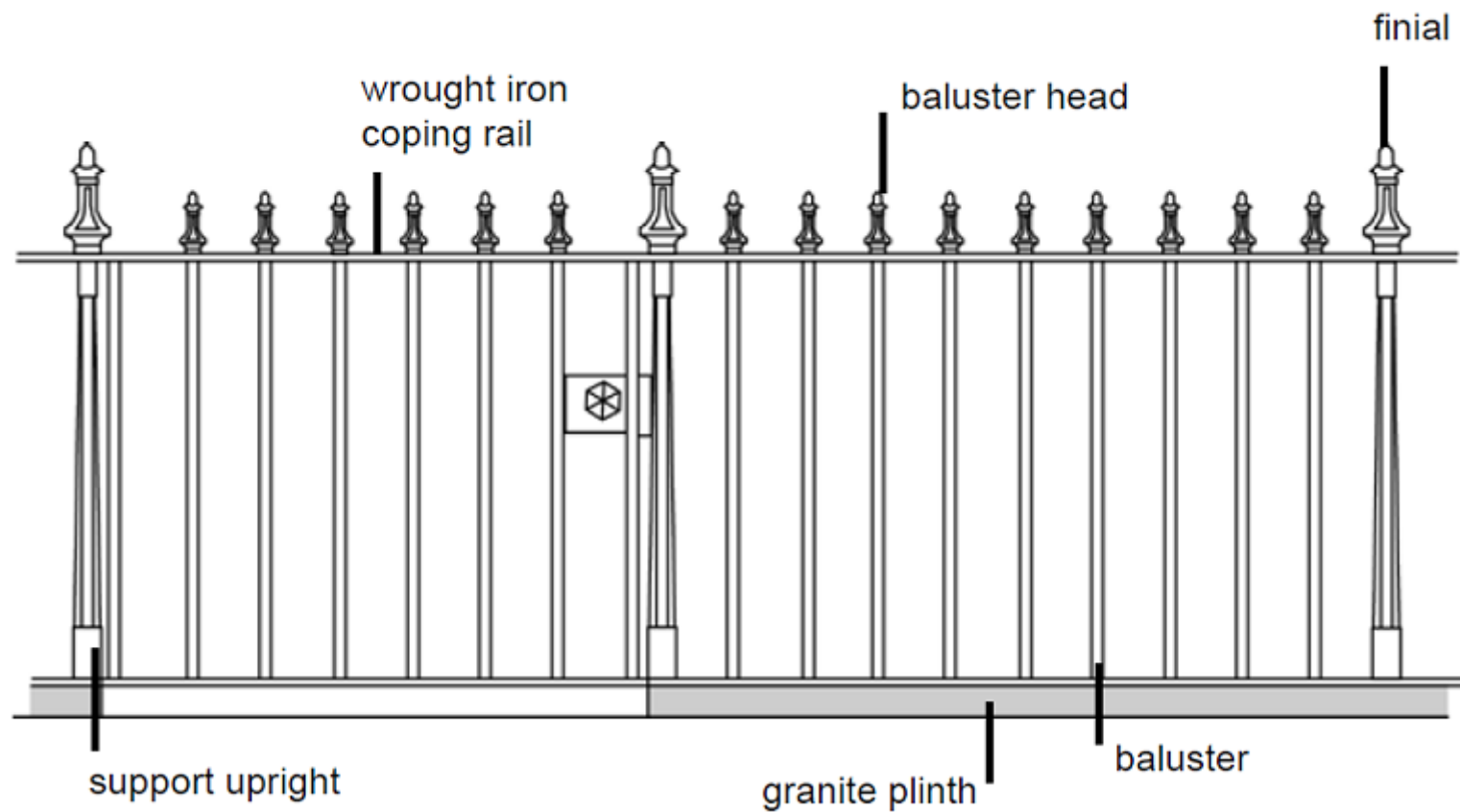

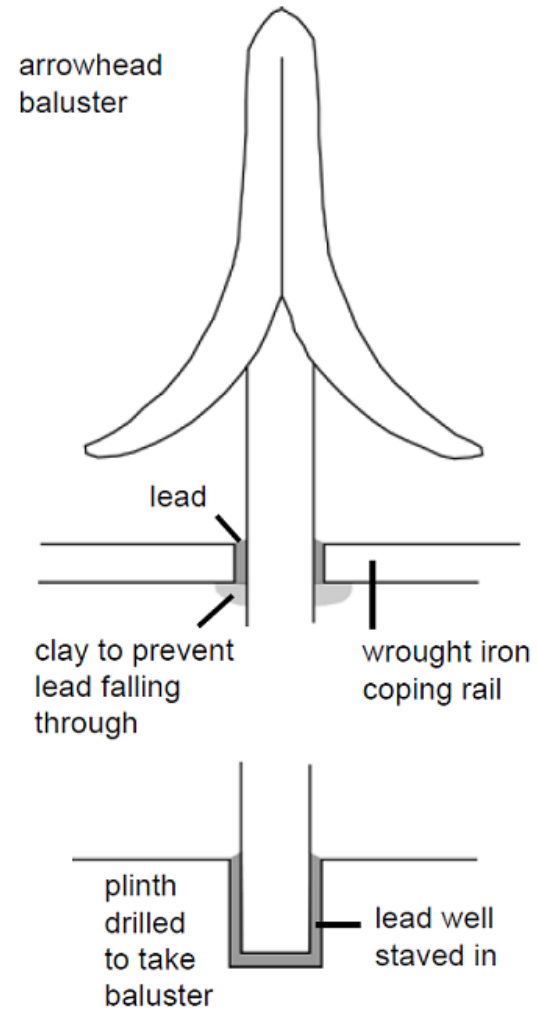
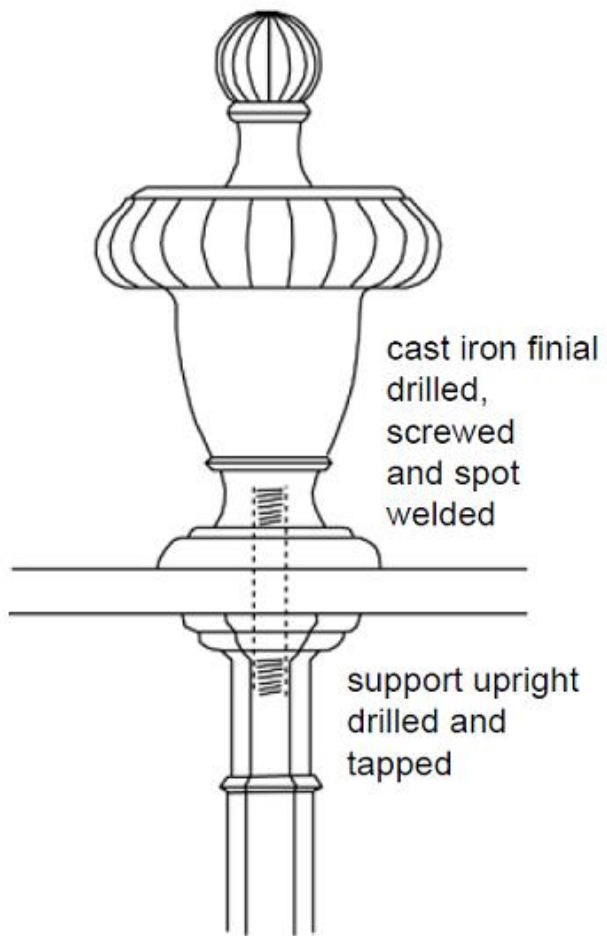

Appendix 2: Cold and Welded Repairs

Cold repairs

Bridging fractured cast iron with metal straps is not an ideal repair. If however it is the only practical method in the circumstances then the strap should be non-ferrous, should follow the profile of the cast iron and should be fixed to the rear of the railing with an epoxy resin adhesive mixed with a compatible epoxy based metal filler. Fixing the strap with pins or bolts is to be avoided. The metal should be scraped free of paint and rust before the adhesive is applied. Minor repairs or filling in small cracks of a cosmetic nature can be carried out with an epoxy based metal filler.

Welded repairs

Welded repairing of cast ironwork is possible although it should be confined to minor repairs. If for example, a cast iron component is broken in several places, it may be cheaper and simpler to replace the component rather than repairing it. Welding cast iron requires certain skills and the area to be welded should be preheated to avoid cracking caused by unrelieved sudden expansion. The joint must be thoroughly prepared prior to welding and nickel alloy electrode rods should be used so that the weld can be easily ground down afterwards.